

MICROPROCESSOR CONTROLLED  
DC ADJUSTABLE SPEED DRIVES  
FOR  
MOVABLE HIGHWAY BRIDGES

T.J. Haas  
and  
H. Griese

MATERIAL HANDLING & INTERNATIONAL UNIT  
SPEED VARIATOR PRODUCTS OPERATION  
GENERAL ELECTRIC CO., ERIE, PA.

ABSTRACT

General Electric Co. drive products have kept pace with the rapid advances in electronics technology beginning in 1962 with solid-state electronics and power conversion for the SILCON III and IV dc drives, predecessors to today's fully digital DC-300 drives.

With the application of microprocessors into the drive technology, General Electric Co. is now opening up new approaches never been taken before.

The specific benefits when applying these fully digital DC-300 adjustable speed DC drives to movable bridge, for users, are discussed in this paper to assist Users, OEMs and consultants in selecting a drive system for their specific installation. With the high flexibility of the DC-300 drives they will be able to establish a new standard in this industry.

## INTRODUCTION

The drives presently used on movable bridges, whether AC wound rotor, DC adjustable speed, AC inverter, or any other control, some of them in use for the last 30 years, are all obsoleted with the introduction of the fully digital DC-300 drives. They are the first of the MICRO POWERED MUSCLE line of digitally controlled programmable drives introduced by General Electric Co.. Multiple microprocessors are incorporated at the heart of the design to provide the most advanced and powerful drive available. Packaging concepts, digital processing techniques and a keypad human interface are integrated in a unique fashion to provide a compact package that is extremely user friendly and suitable for a wide variety of high performance industrial- and commercial applications. Some of the general benefits resulting from General Electric Co.'s state-of-the-art design include:

- Increased Productivity
- Increased Reliability
- Increased Flexibility
- Improved Maintainability
- Ease of Application

## KEY PRODUCT FEATURES

For the movable bridge user increased productivity means to program the drive with installation tailored speed - torque characteristics, which precisely match the application requirements with the capabilities of the supplied motor and control. Productivity also increases with higher reliability of the control system. This is achieved by reducing the number of components by 60% from previous analog drive technologies. Therefore, simply expressed, less parts, less to fail. This has significantly increased "Mean Time Between Failures". Part of the reduction in components includes less wire interconnections. Only necessary single wire connections are done, the rest are accomplished by dependable ribbon cables.

The digital design also enables operational parameter settings and regulator structuring to be accomplished without changing any hardware, only reprogramming of software is needed. The digital nature of the drive and also the hardware structure allow the flexibility required to create a new industry standard. The smallest drive in the DC-300 family is rated from 1 - 30 hp, the next rated from 40 - 75 hp, the third rated from 100 - 250 hp and the fourth rated from 300 - 800 hp. An additional fifth configuration is available for larger power requirements up to 4000 hp. All General Electric Co. digital drives are designed with one hardware set, from the smallest to the largest. The economics of this are obvious, fewer spare parts, reduced operator training and reduced maintenance costs. Further reduction in maintenance time and therewith cost is possible using the integral advanced diagnostic system standard for all DC-300 drives. The keypad programmer with a ten (10) character, alphanumeric read-out is multifunctional and allows in diagnostic mode to read status of the drive through - armature volts, current, torque, horsepower, and many other parameters as selected for the particular application. It also reads faults in both numeric code as well as in a mnemonic format (Example: FL02 OVRSP in case of an overspeed fault). If a fault occurs the drive will immediately shut down and will display one of eighty four (84) fault/status messages - with a "First Fault Indication" that will eliminate hours of trouble shooting. The diagnostic capabilities also include a SCR power bridge test. Each individual SCR is tested for continuity both in the power section as well as the gate circuitry. This makes sure whenever a run command is given that the drive can generate current and therewith torque before the brakes are released and the motor starts to run. The diagnostic monitoring continues all the time the drive is running. Although the drive itself is more sophisticated than any drive ever applied on movable bridges the human interface designed into it makes the application, operation and maintenance extremely easy. The physical size possible through the application of the technology that turned adding machines into pocket-sized calculators is the technology that has created a new smaller package for the DC-300. This results in most cases, where retrofits are necessary, that the new control is installed fast and easy, as it is taking

The drive is also designed to grow with the requirements of the user. For now the built in diagnostics might be fully sufficient for a bridge operator, but with the installation of more advanced maintenance and recordkeeping data collection systems the DC-300's advanced communication capabilities can be utilized. The drive incorporates an RS232C and an RS422 communication link. These provide direct communication from the drive to programmable controllers, mini-computers, main frame computers, and even Speed Variator's Factory through a phone modem for trouble shooting.

#### APPLICATION CONSIDERATIONS

What does the DC-300 adjustable speed drive offer to enhance movable bridge drive productivity?

A conversion technology which has successfully been used in this industry for more than twenty years.

Performance characteristics far superior than any other drive technology available.

An energy efficient, fully regenerative drive with static reversing and regenerative braking through utilization of a full wave double converter.

Peak torque capabilities closely matched to the requirements without oversizing motor and control by utilizing the advantages of the General Electric Co. KINAMATIC DC motor with control features such as "Tapered Current Limit", "Programmable Current Limit" and protective features such as "Timed Armature Over Current", and "Timed Field Over Current".

Transient protection through use of General Electric Co. power metal oxide varistors, incoming a-c line filters and recommended isolation transformers.

A high performance digital drive, providing precise, drift free and repeatable set-up, advanced diagnostics and digital communications to other computer based products.

Interface to master controls like the General Electric Co. Series One, Three and Six Programmable Controls which provide supervisory control and data collection on the bridge. High performance automation capability to accomplish accurate positioning and reduced cycle times.

Last and most important, years of experience in applying, installing and servicing drives and control systems in the material handling and transportation industry.

The DC-300 adjustable speed drive permits the movable bridge user, to have a realistic approach to automation by choosing the right product for new and retrofit installations, now. Because of its expandability, flexibility communication capability, and user friendly interface, it meets the needs of this market today and tomorrow.

#### REMARKS

For additional information required on the following subjects please also refer to the publications as shown below.

- Suppression of overvoltages caused by lightning:  
1980 IEEE, CH1575-0/80/0000-1213 "Suppression of secondary surges caused by lightning overvoltages at transformer primaries", W.K. Boice - Fellow IEEE, Retired General Electric Co..
- Microprocessor controlled DC drives:  
Machine Design June 7, 1984 "Micro Controlled DC Drives"  
Mark Knebusch, Staff Editor.
- DC-300 Adjustable Speed Drives:  
GE Publication GEA-11391.1  
Speed Variator Products Operation, General Electric Co.  
Erie, Pa., 16531.
- Line transient protection:  
GE Publication GET-6468A  
SCR DRIVES  
A-C Line Disturbance  
Isolation Transformers  
Short Circuit Protection  
Power Factor  
Grounding

HOIST BLOCK DIAGRAM (SCHEMATIC)

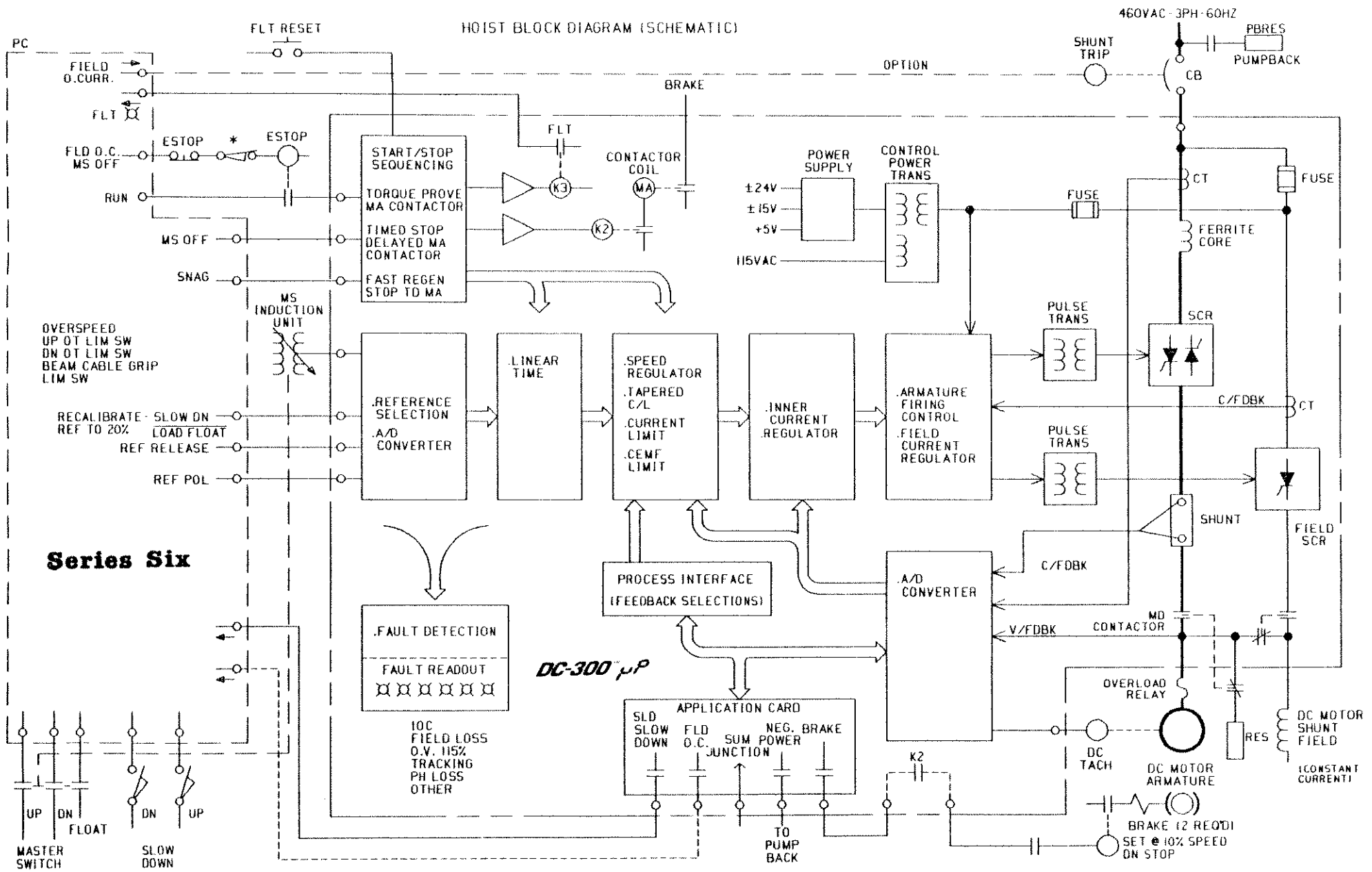

SIMPLIFIED BLOCK DIAGRAM OF DC-300 DRIVE